

PTM | PTV
MINI PLUG-IN
MINI PLUG-IN
MINI PLUG-IN

ELGIN

Mini Plug-In

Mini Plug-In / Mini Plug-In

Monobloco frigorífico cujo objetivo principal é facilitar e agilizar a instalação do sistema de refrigeração. Suas características atendem as exigências da norma IEC 60335.

Principais Aplicações:

- Equipamentos frigoríficos de resfriados
- Expositores de autosserviço e geladeiras comerciais

Monobloque frigorífico que tiene como objetivo principal facilitar y acelerar la instalación del sistema de refrigeración. Sus características atienden las exigencias de la norma IEC 60335.

Principales Aplicaciones:

- Equipos frigoríficos para productos enfriados
- Balcones de autoservicio y refrigeradores comerciales

The monoblock system is a piece of equipment whose main objective is to facilitate and speed up the installation of the cooling system. Its features meet the requirements of standard IEC 60335.

Main Applications:

- Cooling units of chilled products
- Self-service showcases and commercial refrigerators

CARACTERÍSTICAS TÉCNICAS
CARACTERÍSTICAS TÉCNICAS
TECHNICAL FEATURES

MBP	Modelo Modelo Model	Tensão Voltaje Voltage [V]	Ref. Com. Ref. Com. Comm. Ref. [HP]	Capacidade Frigorífica [Kcal/h] Capacidad Frigorífica [Kcal/h] Refrigeration Capacity [Kcal/h]	Compressor Compresor Compressor	
				Temperatura de Evaporação [°C] Temperatura de Evaporación [°C] Evaporating Temperature [°C]	Corrente Corriente Current [A]	Consumo Consumo Input [W]
				-5 °C	Tev= -5 °C	

R-134a

POLIOL ESTER ISO 32	PTM 0020 D	D - 127	1/3	508	4,9	386
	PTM 0020 E	E - 220			2,6	
	PTM 0030 D	D - 127	1/2	724	7,0	490
	PTM 0030 E	E - 220			3,5	
	PTM 0040 E	E - 220	7/8	1.050	4,9	720
	PTM 0059 D	D - 127	1/5	401	3,9	285
	PTM 0059 E	E - 220			2,0	
	PTM 0062 E	E - 220	1 1/4	1.400	5,3	930
	PTM 0085 D	D - 127	1/4	448	4,0	296
	PTM 0085 E	E - 220			2,0	
	PTM 0115 D	D - 127	1/3	615	5,3	396
	PTM 0115 E	E - 220			2,65	
	PTM 0130 D	D - 127	1/3+	825	6,5	472
PTM 0130 E	E - 220	3,25				

R-134a

POLIOL ESTER ISO 32	PTV 0115 D	D - 127	1/3	506	5,6	430
	PTV 0115 E	E - 220			2,8	
	PTV 0130 D	D - 127	1/3+	671	7,2	520
	PTV 0130 E	E - 220			3,6	

CARACTERÍSTICAS TÉCNICAS
CARACTERÍSTICAS TÉCNICAS
TECHNICAL FEATURES

R-22

MBP	Modelo Modelo Model	Tensão Voltaje Voltage [V]	Ref. Com. Ref. Com. Comm. Ref. [HP]	Capacidade Frigorífica [Kcal/h] Capacidad Frigorífica [Kcal/h] Refrigeration Capacity [Kcal/h]	Compressor Compresor Compressor	
				Temperatura de Evaporação [°C] Temperatura de Evaporación [°C] Evaporating Temperature [°C]	Corrente Corriente Current [A]	Consumo Consumo Input [W]
				-5 °C	Tev= -5 °C	

ALQUILBENZENO ISO 32	PTM 2015 H	H - 220	1/5	349	2,2	342
	PTM 2020 H	H - 220	1/4	481	2,5	455
	PTM 2030 H	H - 220	1/2	581	3,4	477
	PTM 2035 H	H - 220	1/2+	797	3,6	575
	PTM 2040 H	H - 220	7/8	975	3,7	715
	PTM 2062 H	H - 220	1 1/4	1.360	5,9	970

CARACTERÍSTICAS TÉCNICAS
CARACTERÍSTICAS TÉCNICAS
TECHNICAL FEATURES

Modelo Modelo Model	Ref. Com. Ref. Com. Comm. Ref. [HP]	Tipo de Óleo Tipo de Aceite Oil type	Carga de Fluido Refrigerante Carga de Fluido Refrigerante Refrigerant Fluid Charge [g]	Capilar Capilar Capillary	Dimensões Dimensiones Dimensions						
					A [mm]	B [mm]	C [mm]	D [mm]	E [mm]	F [mm]	G [mm]
PTM 2015	1/5	ALQUILBENZENO ISO-32	380	0,042" x 2,5m	203	710	50	220	780	310	210
PTM 2020	1/4		400	0,042" x 2,2m	203	710	50	220	780	310	210
PTM 2030	1/2		390	0,050" x 3m	203	710	50	270	780	310	210
PTM 2035	1/2+		550	0,050" x 3m	203	710	50	270	780	310	260
PTM 2040	7/8		550	0,050" x 3m	203	710	50	270	780	310	260
PTM 2062	1 1/4		820	0,050" x 1,5m	189	704	54	322	780	394	260
PTM 0015	1/4	POLIOL ESTER ISO-32	380	0,042" x 2,5m	203	710	50	220	780	310	210
PTM 0020	1/3		400	0,042" x 2,5m	203	710	50	220	780	310	210
PTM 0030	1/2		390	0,050" x 3m	203	710	50	270	780	310	210
PTM 0040	7/8		550	0,050" x 2m	203	710	50	270	780	310	260
PTM 0059	1/5		230	0,042" X 3m	147	484	30	221	537	392	260
PTM 0062	1 1/4		750	0,050" x 1,5m	203	710	50	320	780	310	
PTM 0085	1/4		270	0,042" X 3m	147	484	30	221	537	392	210
PTM 0115	1/3		440	0,042" X 3m	203	710	50	270	780	310	210
PTM 0130	1/3+		390	0,050" X 3m	203	710	50	270	780	310	210
PTV 0115	1/3		300	0,042" x 2,2m	370	430	52	148	272	540	210
PTV 0130	1/3+		310	0,050" x 3m	420	430	52	148	272	540	210

PTV

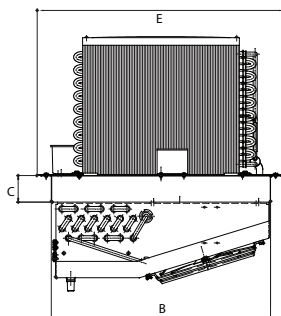
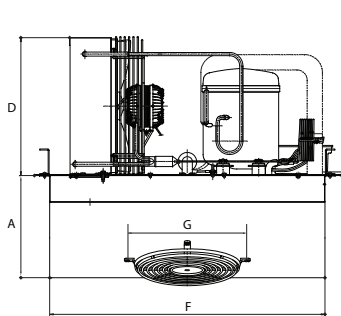

PTM

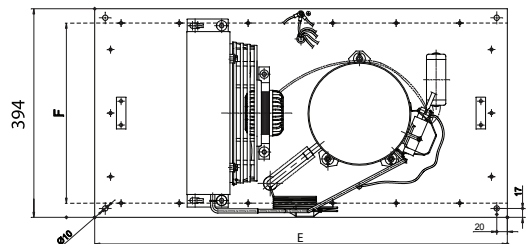
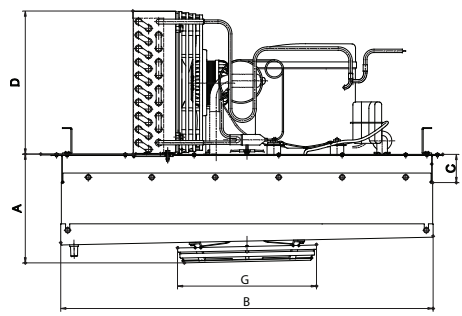

CÓDIGO DO PRODUTO / CÓDIGO DEL PRODUCTO / PRODUCT CODE

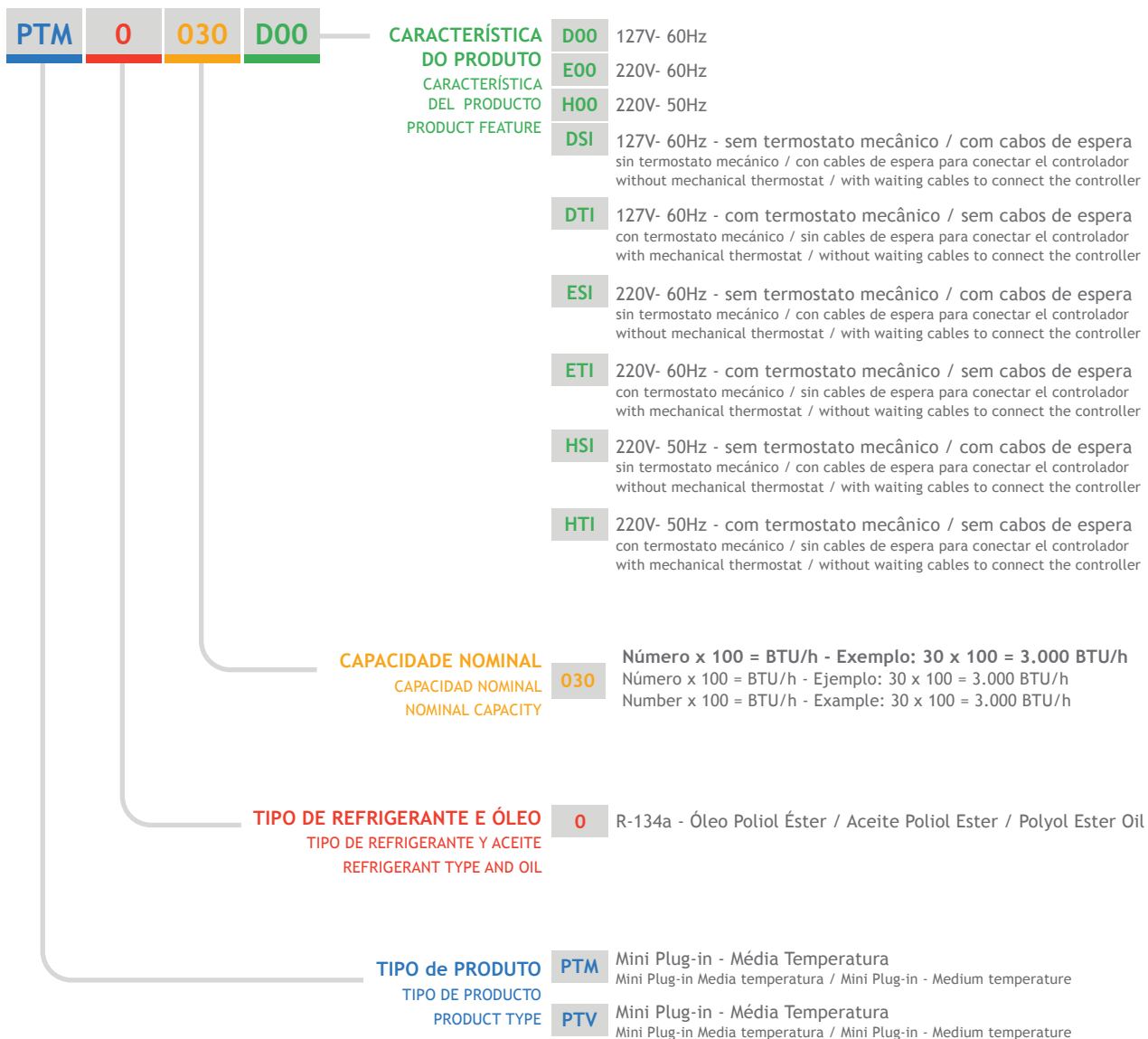

ETIQUETA DE IDENTIFICAÇÃO / ETIQUETA DE IDENTIFICACIÓN / IDENTIFICATION LABEL

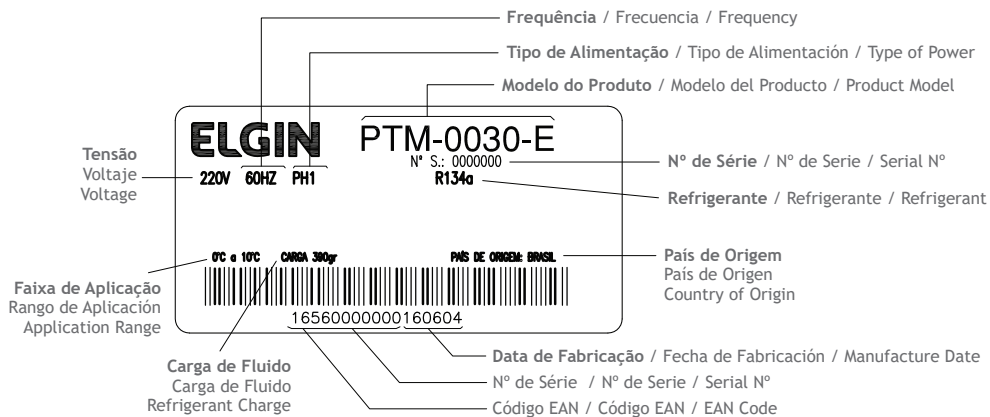

ELGIN



ORGULHOSAMENTE
BRASILEIRA

SAC: 0800 771 1960 | TEL.: 11 3383 5901 | E-MAIL: REFRIGERACAO@ELGIN.COM.BR

 Elgin Refrigeração

 grupo_elgin

 Grupo Elgin

 Elgin S.A. (Brazil)

 elgin.com.br

Reservamo-nos o direito de fazer atualizações neste catálogo, a qualquer momento, sem aviso prévio. Acesse nosso site para ter a versão mais atual. As imagens presentes no catálogo são meramente ilustrativas.

Nos reservamos el derecho de actualizar este catalogo en cualquier momento sin previo aviso. Acceda a nuestro sitio web para tener la versión más actual del catalogo. Las imágenes en el catálogo son meramente ilustrativas.

We reserve the right to updates this catalog at any time without notice. Visit our website to have the most current version of the catalog. The images in the catalog are merely illustrative.